

### FEATURES:

- Anti-static Devices For Ball- Stem- Body
- Blow-out Proof Stem
- Pressure Balance Hole In Ball Slot
- Using Dewaxing Precision Casting

### STANDARDS:

- Design: ASME B16.34
- Wall Thickness: ASME B16.34
- Fire Safe: API 607 ISO 10497
- Face to Face: ASME B 16.10
- End Flange: ASME B16.5
- Inspection & Testing: API 598

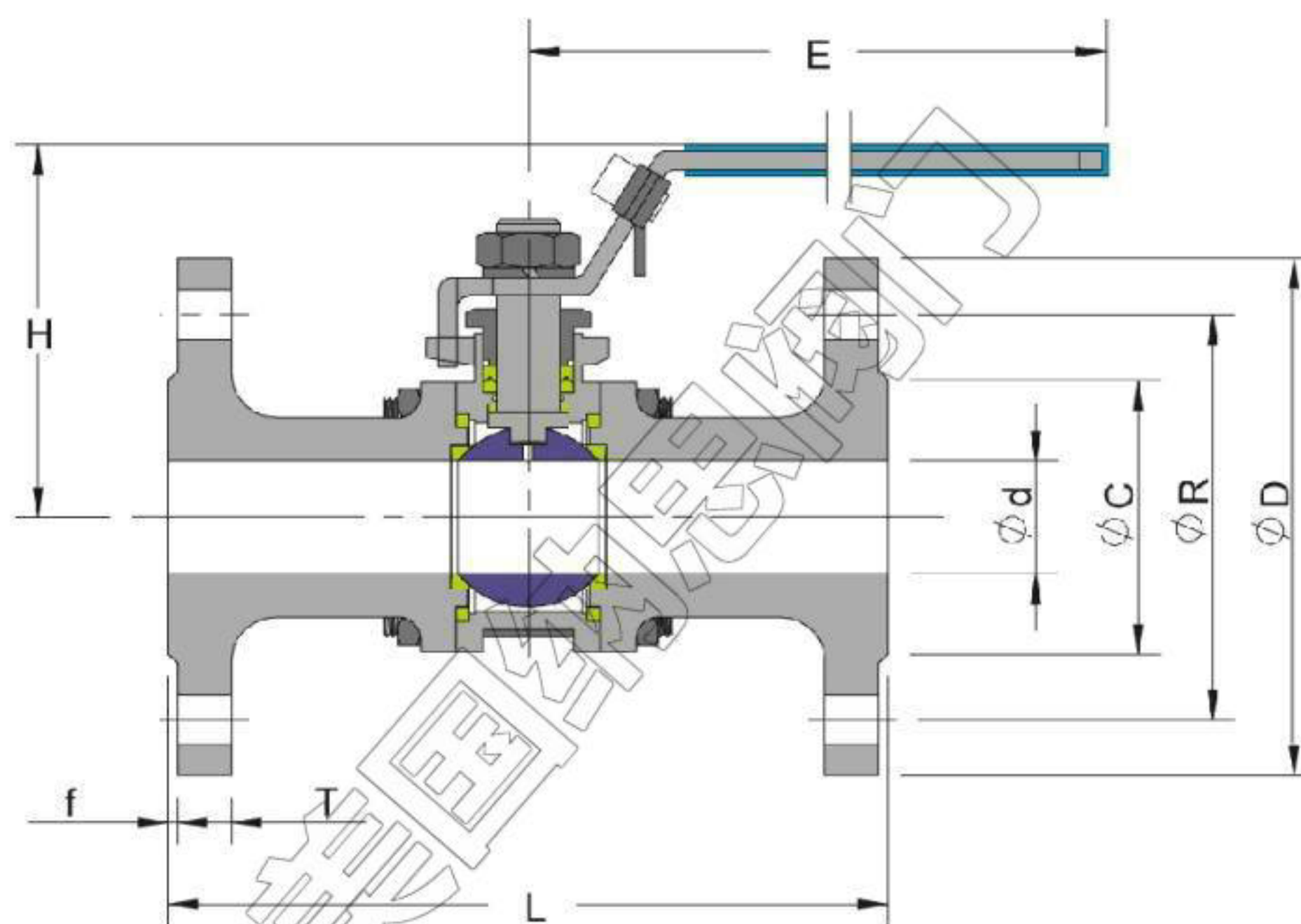

Unit:mm ■ ASME 150LBS

Size	(LBS)	L	Ød	ØC	Ø R	ØD	H	E	T	f
1/2"	150	108	15	34.9	60.3	90	76.5	120	11.2	2
3/4"	150	117	20	42.9	69.9	100	79	120	11.2	2
1"	150	127	25	50.8	79.4	110	91.5	150	12	2
1-1/4"	150	140	32	63.5	88.9	115	96.5	150	12.7	2
1-1/2"	150	165	38	73	98.4	125	104	170	14.3	2
2"	150	178	48	92.1	120.7	150	117	170	15.9	2
2-1/2"	150	190	65	104.8	139.7	180	140	250	17.5	2
3"	150	203	76	127	152.4	190	142.5	250	19.1	2
4"	150	229	100	157.2	190.5	230	163.5	300	23.9	2